

HD Analog Camera User's Manual

Model No. CV-CFW103L
CV-CFW103LN

Table of Contents

1	General Introduction	1
1.1	Overview	1
1.2	Features	1
1.3	Functions	1
1.4	Specifications	2
2	Framework and Dimensions	3
3	Installation	5

Welcome

Thank you for purchasing our HD analog camera!

This user's manual is designed to be a reference tool for your system.

Please read the following safeguard and warnings carefully before you use this series product!

Please keep this user's manual well for future reference!

Important Safeguards and Warnings

1 . Electrical safety

All installation and operation here should conform to your local electrical safety codes.

The power shall conform to the requirement in the SELV (Safety Extra Low Voltage) and the Limited power source is rated 12V DC in the IEC60950-1.

We assume no liability or responsibility for all the fires or electrical shock caused by improper handling or installation.

2 . Transportation security

Heavy stress, violent vibration or water splash are not allowed during transportation, storage and installation.

3 . Installation

Do not apply power to the camera before completing installation.

Please install the proper power cut-off device during the installation connection.

Always follow the instruction guide the manufacturer recommended.

If this product is installed in the ceiling, please make sure the installation position can sustain the min 50N.

4 . Qualified engineers needed

All the examination and repair work should be done by the qualified service engineers.

We are not liable for any problems caused by unauthorized modifications or attempted repair.

5 . Environment

This series HD analog camera should be installed in a cool, dry place away from direct sunlight or strong light, inflammable, explosive substances and etc.

This series camera shall work on the specified working temperature. Please keep it away from the electromagnetic radiation object and environment.

Please make sure the CMOS component is out of the radiation of the laser beam device. Otherwise it may result in CMOS optical component damage.

Please keep the sound ventilation.

Do not allow the water and other liquid falling into the camera.

6 . Accessories

Be sure to use all the accessories recommended by manufacturer.

Before installation, please open the package and check all the components are included.

Contact your local retailer ASAP if something is broken in your package.

7 . Daily Maintenance

Please shut down the device and then unplug the power cable before you begin daily maintenance work.

Use the dry soft cloth to clean the device.

If there is too much dust, please use the water to dilute the mild detergent first and then use it to clean the device. Finally use the dry cloth to clean the device.

Please put the dustproof cap to protect the CMOS component when you do not use the camera.

1 General Introduction

1.1 Overview

This series HD analog camera conforms to the HDCVI standard. It supports video signal high-speed long distance transmission without any delay. It can be controlled by the DVR conforming to the HDCVI.

1.2 Features

- High-performance CMOS image sensor, megapixel definition.
- Support 720p@25fps(PAL) /30fps (NTSC)
- Support HDCVI video output.
- Support 75-3 coaxial cable transmission over 800m.
- High speed, long distance real-time transmission.
- Support ICR switch to realize surveillance both in the daytime and at night.
- Support auto exposure, auto white balance, auto electronic shutter and auto gain function.
- High image color rendition, vivid image.
- Support DC12V power supplying.
- Support IP66 compliance.
- Support intelligent IR function. max IR distance 30m.

1.3 Functions

HDCVI Specification

HDCVI (High Definition Composite Video Interface) is an over-coaxial –cable HD video transmission standard. The technology renders two HD video formats by progressive scanning.

ICR

The IR cut removal is to filter the IR light in the daytime and then auto switch to the general filter at night. This function allows the camera to output the high sensitivity and clear video.

Smart IR technology

The sensor controls the IR light on/off via the combination work of the hardware and software, which realizes the automatically IR light compensation according to the environment illumination.

Auto gain function

To output the standard video signal in the different illumination environments, the amplifier needs to adjust in a wide range. The system can enhance the camera sensitivity in low illumination and enhance the video signal output to get the clear and high definition video.

Auto white balance

The white balance refers to the camera to restore the white object color. It allows the camera to automatically adjust the color temperature in indoor and outdoor environment, just like our human eyes does.

Auto exposure

System can automatically set shutter speed and iris value according to the snapshot video exposure condition.

Auto electronic shutter

The system can automatically adjust the electronic shutter when the environment light changes.

1.4 Specifications

Parameter	CV-CFW103L	CV-CFW103LN
Camera		
Image Sensor	1/2.9" 1.0 Mega Pixels CMOS	
Effective Pixels	1280 (H) × 720 (V)	
Min Illumination	0.05Lux/ F1.6, 0Lux IR on	
Electronic Shutter	1/50s~1/100,000s	1/60s~1/100,000s
Video Frame Rate	25fps	30fps
Synchronization	Internal	
Day & Night	Auto (ICR)/ Color/ B/W	
Max IR Distance	30m	
Digital Noise Reduction	2D	
White Balance	Auto	
AGC	Auto	
BLC	Auto	
Lens		
Focal Length	3.6 mm	
Angular Field of View	H: 88° V: 46°	
Lens Type	M12	
Input / Output		
Video Output	1 CH BNC HD-CVI video output	
General		
Power	DC 12V±25%	
Power Consumption	2.5W MAX	
Working Temperature	-30°C~+60°C. Less than 95% RH (no condensation)	
Dimensions	Φ93.4 mm × 79.7 mm	
Weight (approx.)	350g	
Installation Mode	Wall mount/ In-ceiling mount	
External Case	Metal	

2 Framework and Dimensions

Please refer to the following figures for dimension information. The unit is mm. See Figure 2-1 and Figure 2-2.

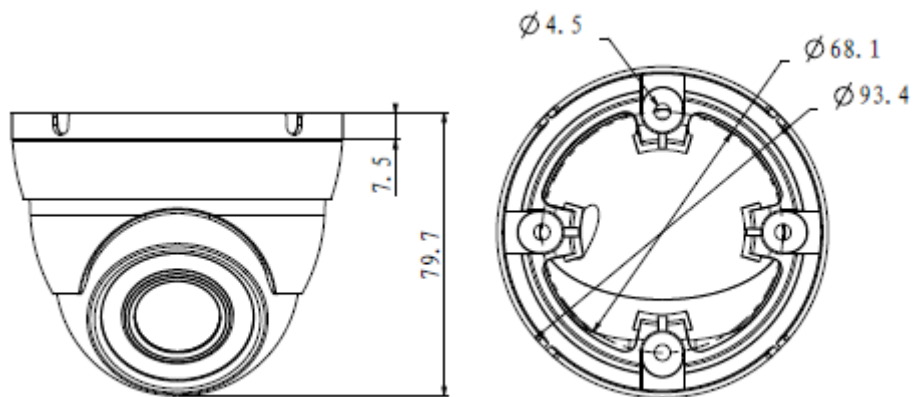

Figure 2-1

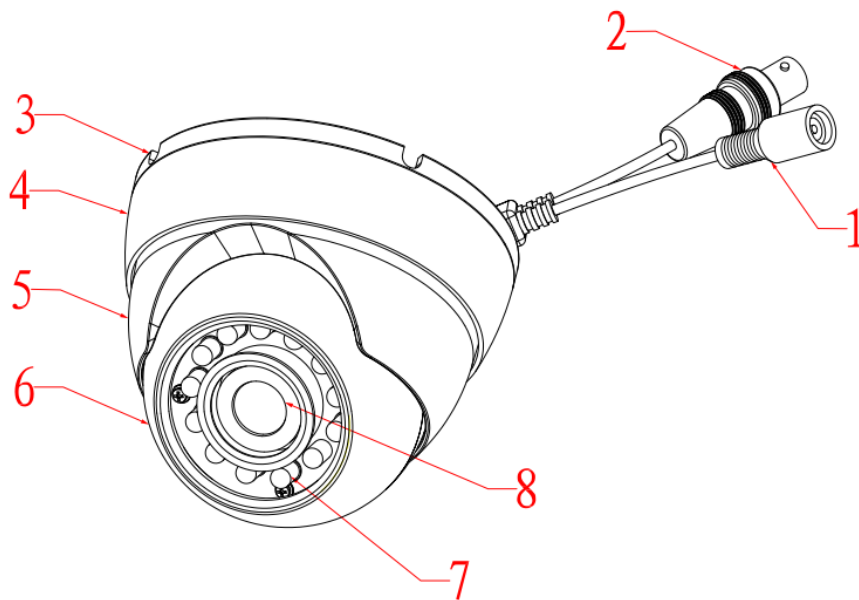

Figure 2-2

Please refer to the following sheet for detailed information.

SN	Name	Function
1	Power input port	Connect to the DC 12V power to input the power.
2	Video output port	BNC port is to output HDCVI video signal. You can connect to the devices such as the DVR or the NVS conforming to the HDCVI specifications.
3	Installation base	Device installation base
4	Rotate base	Adjust the rotate base to adjust the monitor angle.
5	Panel cover	Adjust the panel cover to adjust the monitor angle.
6	Dome Body	Adjust the dome body to adjust monitor angle.
7	IR light	It is to send out the IR compensation light to enhance the night vision.
8	Lens	It is to receive the optical signal from the environments.

3 Installation

Important

Please make sure the installation surface can support the 3X weight of the camera and the bracket.

The dome camera usually uses the ceiling installation. It can be installed on the ceiling or the wall.

Step1 Device Installation

Take the hex key from the accessories bag and use it to loosen the three set screws on the side of the camera body. See Figure 3-1.

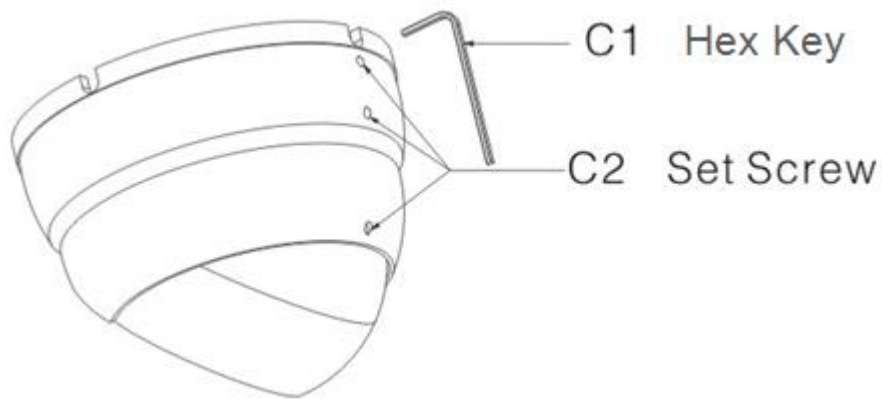

Figure 3-1

Step 2 Pedestal Installation

Turn the pedestal of the device and then pull the cable through it. Use four screws to secure the pedestal to the proper position. See Figure 3-2.

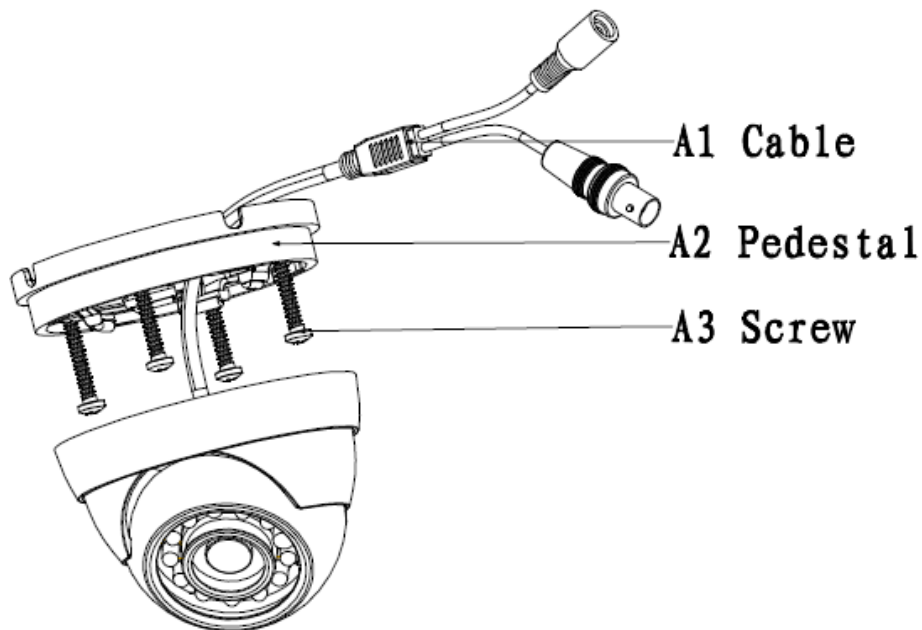

Figure 3-2

Step 3 Adjust Monitor Angle

Turn the pan base to the pedestal and secure firmly. Adjust rotate base and the dome body to get the lens to the proper monitor angle. See Figure 3-3.

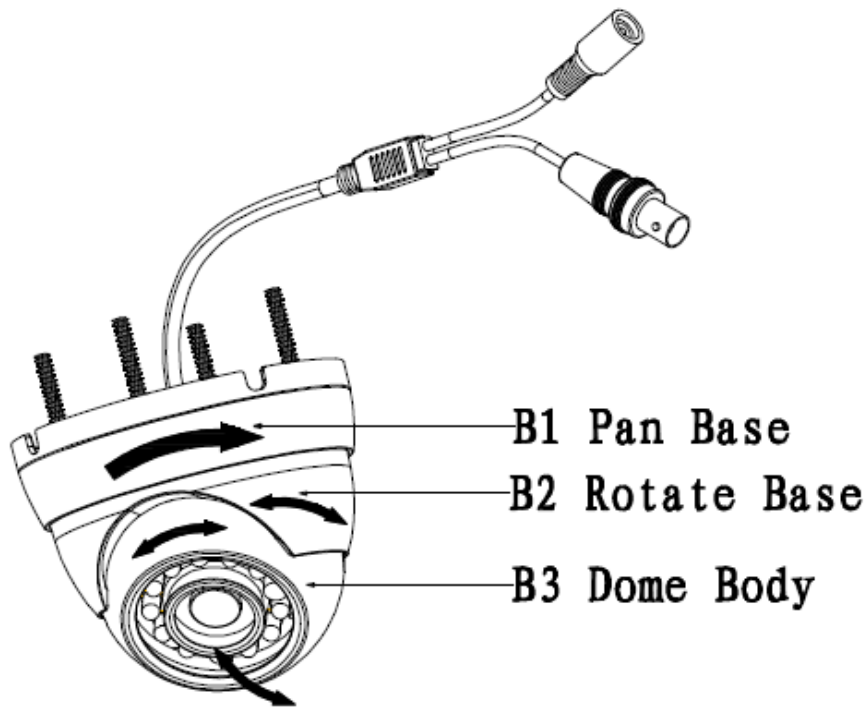

Figure 3-3

Step 4 Fix Monitor Angle

To prevent the dome from moving, use hex key to secure the three set screws to secure the monitor angle position.

Note

- This manual is for reference only. Slight difference may be found in the user interface.
- All the designs and software here are subject to change without prior written notice.
- All trademarks and registered trademarks mentioned are the properties of their respective owners.
- If there is any uncertainty or controversy, please refer to the final explanation of us.
- Please visit our website or contact your local service engineer for more information.